

Powered Ascending Device

ACE-24

Operation Manual

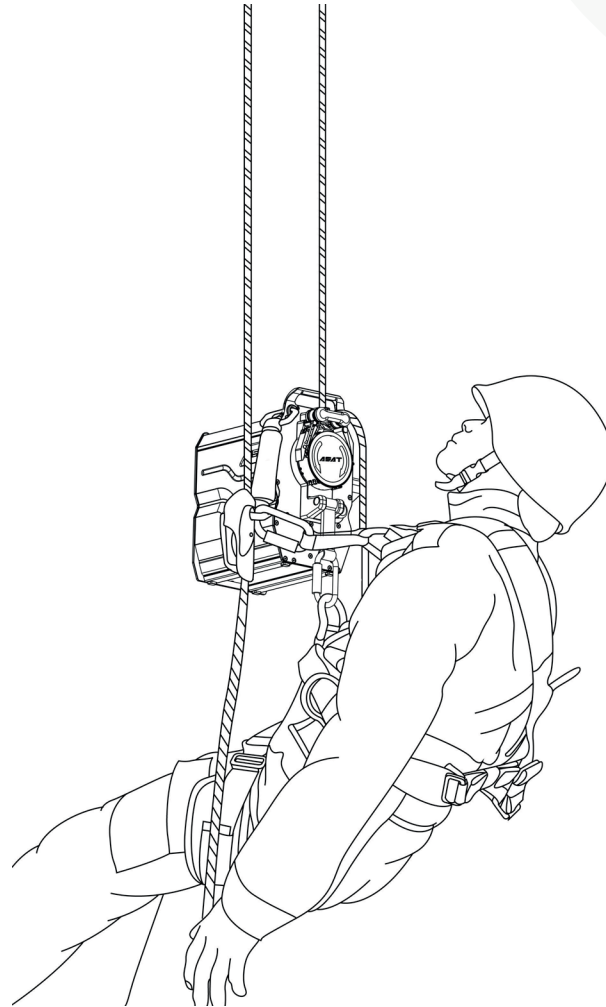

Distributed in UK, EU and MENA by
At Height Ltd.

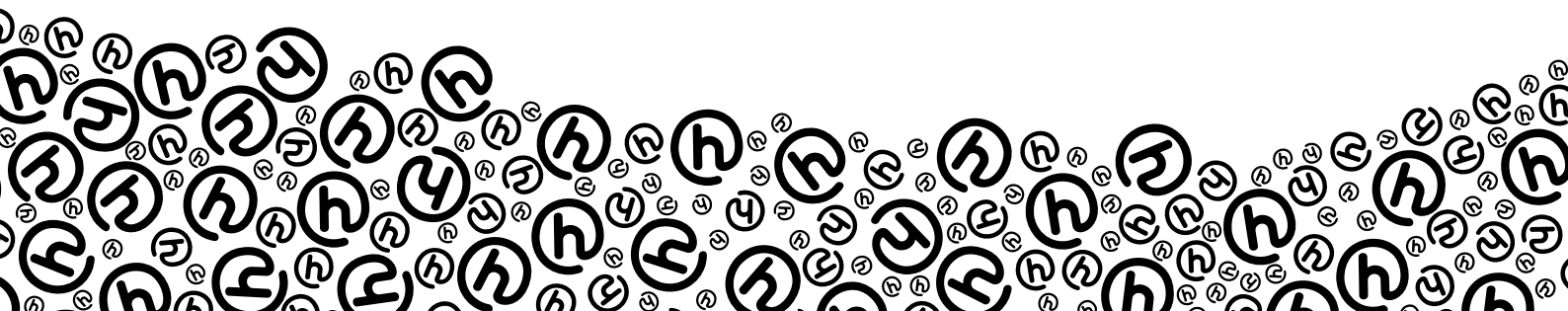

Contents

1、 Safety precaution.....	3
2、 Functions.....	3
3、 Training	6
4、 Description	7
5、 Operation	14
6、 Associated equipment	20
7、 Check and inspection	20
8、 Storage,Transportation,Maintenance and Overhaul	21
9、 Service life	21
10、 Marking	22
11、 Fault,cause and remedy	23
12、 Annual inspection Record sheet	24

Series of Powered Ascending Device are developed and manufactured by SKYER (Beijing) Industry Technology Co., Ltd.

1、 Safety precaution

WARNING:

The Powered Ascending Device (hereinafter referred to as 'the device') shall only be used by trained persons who possesses relevant safety knowledge.

The users must ensure that the adopted PPE and accessories are compatible with the device.

The users must read and fully understand the relevant operation instructions provided by SKYER. Failure to follow the instructions may result in serious injury or death.

The device can only be used for man-riding, material transportation along the vertical, horizontal or inclined working ropes.

Before each use, the user must check the device and ensure that it is in normal working condition.

Before each use, the user must make sure that all markings on it are complete and legible. If any query, please contact SKYER customer service or its authorized agencies.

Never use the device in explosive environment.

The device must never withstand a dynamic load during operation.

Use only the original parts of the device.

Charging the device battery by other chargers instead of that provided by SKYER Co. Ltd. may cause damage of the battery, even explosion.

Maintenance shall be performed by competent persons, who have been trained and certified by SKYER.

Anchor point used for the device must be in accordance with EN795 or ANSI/ASSE Z359.15:2014.

Do not contact the ropes used with the device to sharp edges of structures, corrosive substances, flame or rough surface because it may result in rope damage

Conduct the risk assessment and prepare the relevant rescue plan before each use.

The dedicated ropes used for the device must be only those provided by SKYER or verified by a competent person in accordance with EN1891.

The device and its associated equipment must be inspected annually.

2、 Functions

2.1 Application

Used for single person individually: the user carrying necessary equipment can access the places along the dedicated rope at a specified speed by means of the device, where are difficult or impossible to access by other manners.

Emergency rescue: the user carrying an incapacitated person can transfer to a safety place by means of the device along the dedicated rope set up.

Material transportation: the user can operate the device by remote control to transport tools and materials along the dedicated rope set up to the places where are difficult or impossible to reach by other manners.

2.2 Operation mode

Ascending and descending vertically: Operate the device ascending and descending vertically along the dedicated rope. In addition to the working rope, another rope, on which a fall arrester is attached, is necessary to be set up for safety purpose.

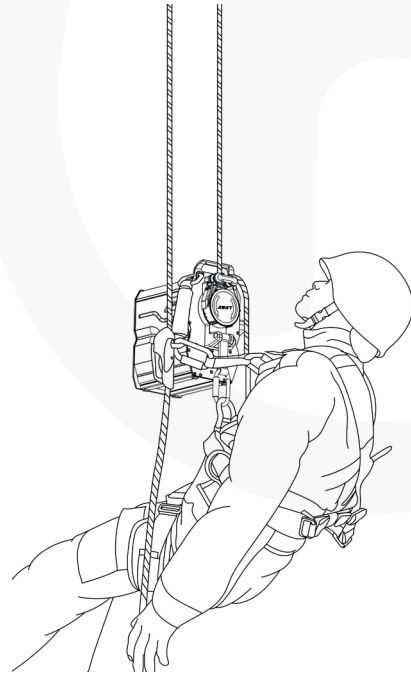

Traversing horizontally: Operate the device traversing along the working rope between two places at almost the same height and a certain horizontal distance. In addition to the working rope, another rope is necessary to be set up for safety purpose. The safety rope is attached with a pulley and a lanyard which connects with the safety harness of the user. During the operation, the working and safety ropes should keep slack and do not withstand any load in order to avoid affecting the running direction and operation state of the device along the working rope.

In emergency, the user can perform a task using the working rope only without the safety rope in the condition of that he is experienced and the operation safety is ensured.

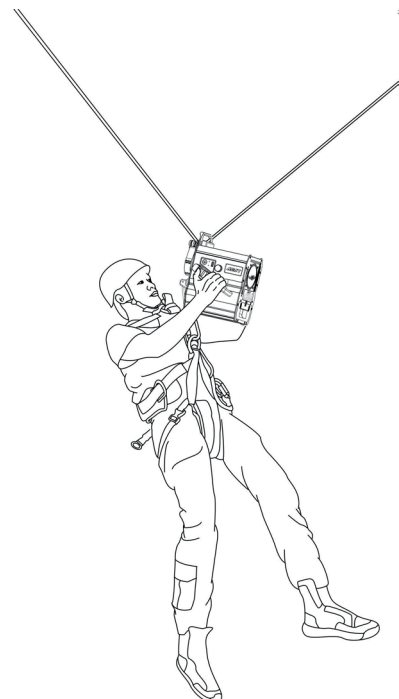
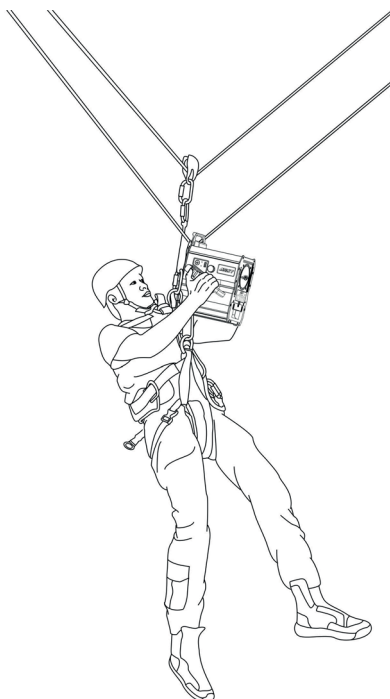

Traversing inclinedly: Operate the device traversing along the working rope between two places at a certain height difference and certain horizontal distance. In addition to the working rope, another rope is necessary to be set up for safety purpose. The safety rope is attached with a pulley and a lanyard which connects with the safety harness of the user. During the operation, the working and safety ropes should keep slack and do not withstand any load in order to avoid affecting the running direction and operation state of the device along the working rope.

In emergency, the user can perform a task using the working rope only without the safety rope in the condition of that he is experienced and the operation safety is ensured.

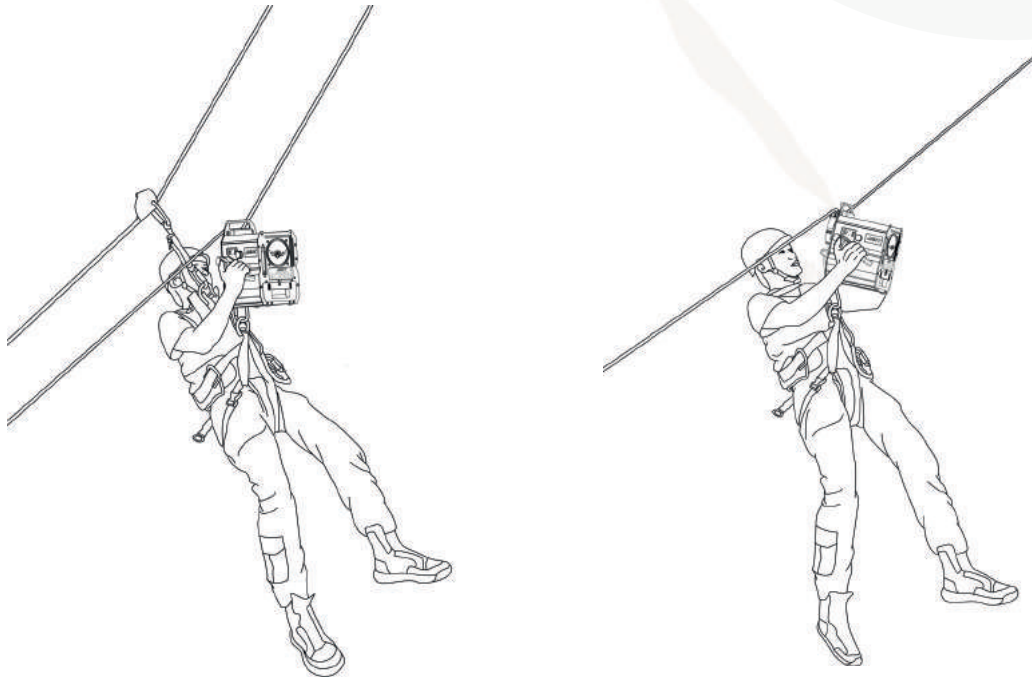

Note: During the process of traversing horizontally or inclinedly, the angle of the working rope shall be less than 150°.

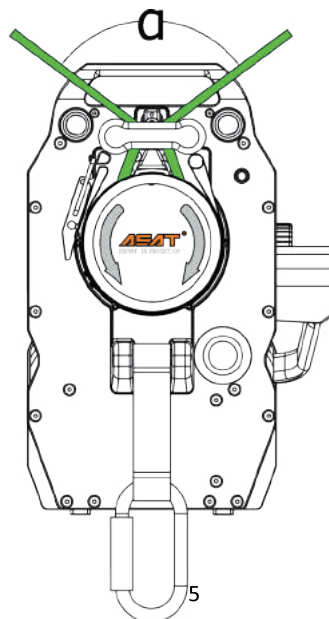

3 Training

Users must have received the training from SKYER or the agents authorized by SKYER and obtain certificates before using the device.

The training is divided in two parts:

3.1 Basic knowledge and skills for rope access:

3.1.1. Operation and inspection of the device: through the training, users shall operate, check and maintain the device correctly.

3.1.2 . Work safety: through the training, users shall comprehend the necessary safety management plans, relevant policies, work permit and work areas, and conduct relevant Job Safety Analysis.

3.1.3 . Knotting: through the training, users shall make knots listed as follows independently and comprehend the application, strength and limit of these knots:

3.1.3.1 Knots for anchor points: such as figure of eight, figure of nine.

3.1.3.2 Connecting knots: double fishermen, square knot.

3.1.3.3 Middle knots: butterfly knot.

3.1.4 . Application of double rope system and associated equipment:

3.1.4. 1. Use of descenders

3.1.4. 2. Use of ascenders

3.1.4. 3. Conversion from ascending to descending

3.1.4. 4. Use of work seat

3.1.4. 5. Passing through knots

3.1.5 . Set up anchor points

3.2. Operation of the device

3.2.1. Check before each use.

3.2.2. Ascending and descending along vertical rope.

3.2.3. Traversing along horizontal rope.

3.2.4. Traversing along inclined rope.

3.2.5. Use under the normal conditions.

3.2.6. Identification and resolution of simple technical problems.

3.2.7. Maintenance and service of the device.

4 Description

4.1 Device composition:

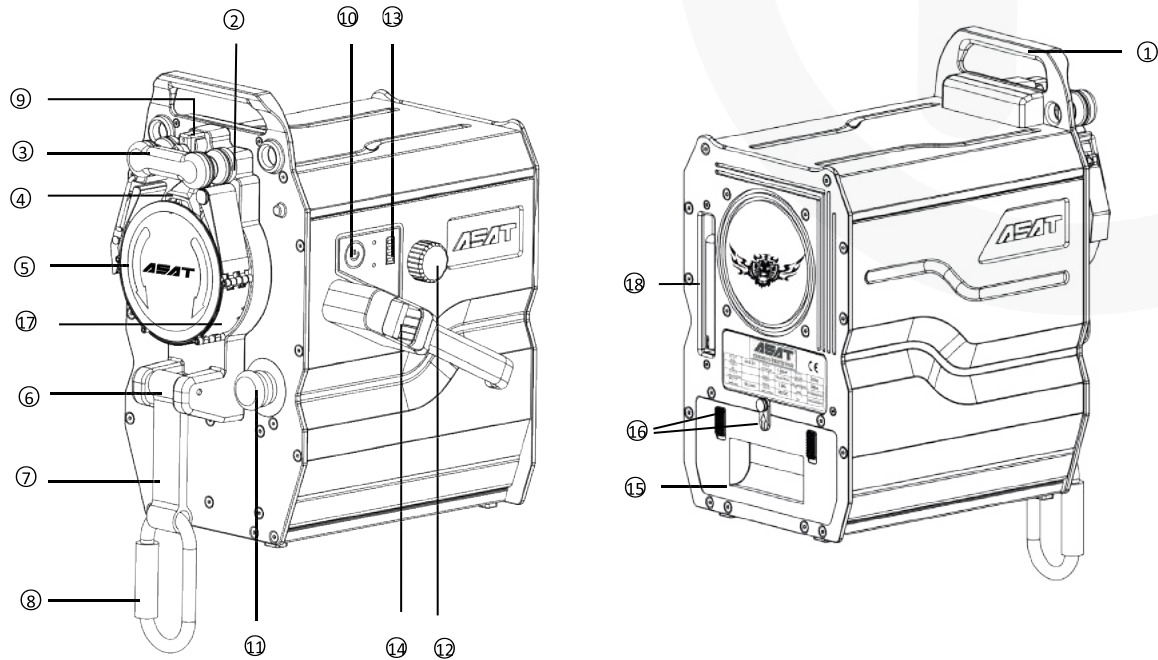

4.2 Components.

No.	Item	No.	Item
1	Handle	10	Power button
2	Rope guide pulley	11	Emergency stop button
3	U-shaped fender	12	Manual descending lever
4	Rope separator	13	Battery level indicator light (LED)
5	Rope sheave	14	Speed/direction thumb shifter (on handle)
6	Load bearing rod	15	Battery
7	Lanyard	16	Battery Lock
8	Carabiner	17	Hinged steel band
9	Guide block	18	Antenna

4.3 Technical data

Technical specifications	ACE-24
Rope	Dedicated static rope: φ11 mm in accordance with EN1891
Rated working load	180kg
Working load limit	260kg
Ascending speed	0-30m/min 150kg (Stepless speed regulation)
Traversing speed	0-30m/min 150kg (Stepless speed regulation)
Descending speed	0-40m/min 150kg (Stepless speed regulation)
Battery capacity	700m/150 kg (up and down)
Charging time	< 1 hour
Temperature range	-30°C--+60°C
Overheat protection	Yes
Battery protection at low temperature	Yes
Weight	18kg (With battery)
Dimension	30×23×35cm
Protection degree	IP56
Remote control range (L)	>150m (open space)
Resistance to fall	0.5m
Manual descent	Yes

4.4 Main components:

4.4.1 Components of rope sheave assembly

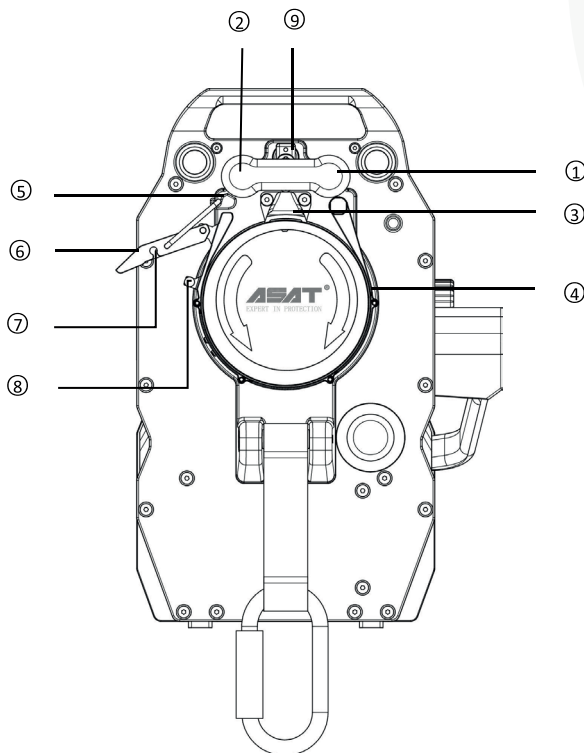

- 1- U-shaped fender
- 2- Rope guide pulley
- 3- Rope separator
- 4- Hinged steel band
- 5-Hook of hinged steel band
- 6- Lock handle of hinged steel band
- 7- Self-lock slot
- 8- Self-lock knob
- 9- Guide block

4.4.2 Control panel button, display and operation

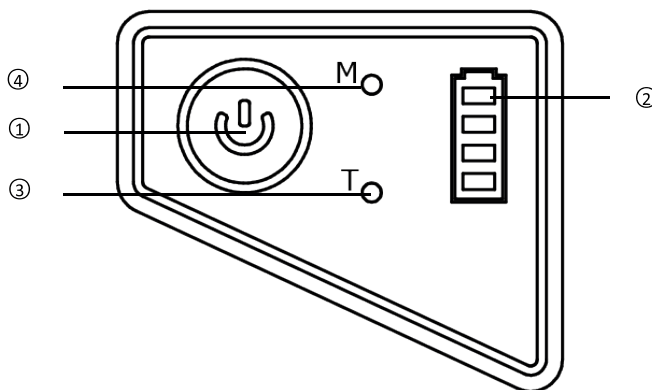

- 1- Power button
- 2- Battery level indicator light
- 3- Temperature warning light
- 4- Driver warning light

4.4.2.1: Power button:

In case of shutdown, when power button is pressed, the device will be energized. After the self-test, the temperature and driver warning lights turn off, and the battery level indicator lights show up normally.

Under normal mode, after the power button is pressed and hold for 2 seconds and then released, all indicator lights turn off and the device is shut down.

Battery level indicator lights: It consists of four LEDs. Counted from the top, the first and second are green colored, the third is yellow colored and the fourth is red colored. Each LED indicates 25% of the battery level.

LED indicator lights	Remained battery level
Two green, one yellow and one red	75-100%
One green, one yellow and one red	50-75%
One yellow and one red	25-50%
One red	0-25%

Note: When only one red LED is lit, charge the battery as soon as possible.

Note: At the ambient temperature below zero, the battery level is indicated inaccurately. For example, when two LEDs (one red and one yellow) are lit, the battery level remained may be only about 15% of the total battery level instead of 50% at an ambient temperature below zero. When the device is heavily loaded, the consumption of battery level will accelerate.

Note: Under normal conditions, the actual battery capacity is as that indicated. When the emergency button is pressed, only one red LED is lit on the battery level indicator lights.

4.4.2.3 Temperature warning light:

When the temperature warning light is on and off alternatively, it means that the operation of the device results in the motor overheated. In the case, the operation of the device shall be stopped. The user shall press the emergency stop button, turn off the power supply and then manual descend to the ground for a rest. After taking rest for a period of time until the temperature warning light is off, the device can resume its normal working condition.

4.4.2.4 Driver warning light: When the driver warning light is on, it means that an abnormal working condition occurs, such as too large drive current, over-speed or other faults. In the case, the operation of the device shall be stopped. At the time, reset the device to eliminate the warning. There are two methods to reset the device: press and hold the emergency stop button for about 3 seconds and then release it; or press and hold any button on the remote control for 3 seconds and then release it. If the faults still cannot be removed after resetting, descend manually to the ground after turning off the device and contact the customer service of SKYER for repair.

4.4.3: Emergency stop button

In any case, the device shall be stopped immediately and sustained on the working rope when the emergency stop button is pressed.

4.4.4 Battery and charger

4.4.4.1 Battery

4.4.4.1.1 The device is fitted with a high-capacity battery, which can be conveniently mounted on and removed from the device.

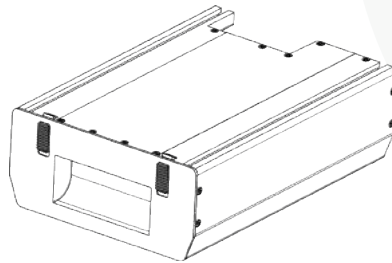

4.4.4.1.2 Battery protection

The battery system has monitor function to protect the battery circuit, which includes current output protection, overvoltage and overcurrent charging protection, high temperature cutoff protection and low temperature protection.

Current output protection: when the device is overloaded, which causes too large output current, the battery system will automatically stop current output to protect the battery and the drive control system.

Overvoltage and overcurrent charging protection: when the charging voltage is higher than the rated voltage in charging process, the battery system will automatically stop or limit the input current to the battery in order to protect the battery. The battery can be charged at any time and has no memory effect resulting in battery capacity reduction.

Low temperature protection: when the ambient temperature is low, the temperature detection system starts its operation, automatically heating the battery to ensure that the battery is kept in the normal temperature range and prevent the battery from not being able to output the required current in the case.

Note: The function of low temperature protection is only available when the low temperature protection button on the battery is pressed.

The current output of battery will be cutoff when the temperature of battery is higher than 65°C. In the case, no power is transmitted to the device.

4.4.4.1.3 The battery capacity will decrease with the operating time. For every 20,000m of accumulated running distance (with 120 kg of load), the battery capacity will reduce. The battery should be discarded after 200,000 m of accumulated running distance.

4.4.4.1.4 The service life of the battery is more than 3-4 years.

High-temperature environment (<60°C) has a little bit of effect to the battery capacity.

Note: Charge the run-down battery as soon as possible to prevent its failure owing to long time in uncharged state.

The battery must be checked and recharged quarterly to prevent the damage of the battery caused by in uncharged state for long time.

4.4.4.2 Battery Mounting and removal:

Battery removal: press down the battery secondary lock and turn it to let the arrow horizontal. At the position, the secondary lock is unlocked. Then pull the battery lock up and pull the battery out.

Press the battery lock downwards and pull the battery out from the device.

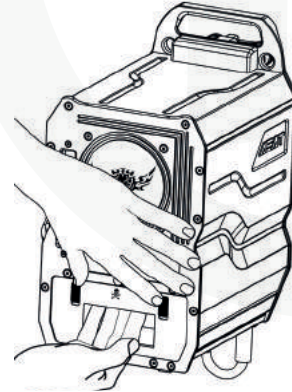
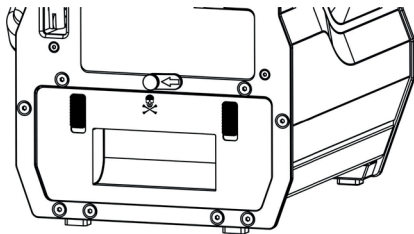

Battery mounting:

Align the battery with the battery box and push it in, ensuring correct electrode connection.

Up on battery mounting, verify that the battery is locked by battery lock and cannot be pulled out. Then turn the secondary lock to let the arrow upward, by which the secondary lock is locked.

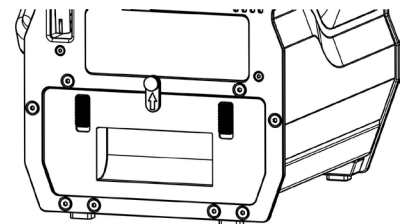
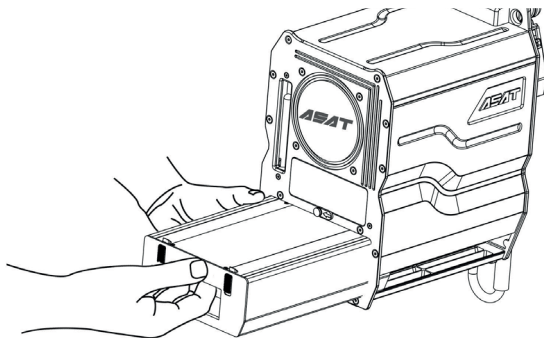

4.4.4.3 Charger

A dedicated quick charge is provided with the device. It can fully charge the battery less than 1 hour.

4.4.4.4 Charging

4.4.4.4.1 Verify the power voltage for the charger before charging the battery. Adjust the charger to 220V or 110V to the correct power supply(see below).

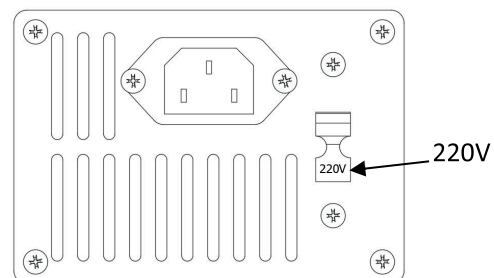
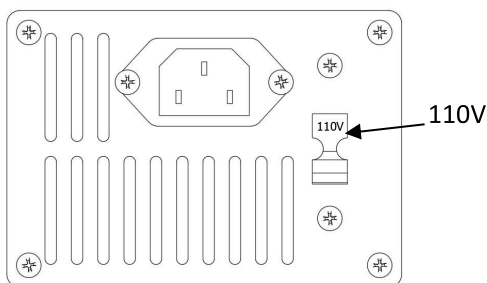

4.4.4.4.2 Insert the charger power input plug into AC power supply socket.

4.4.4.4.3 Insert the charger output plug into the battery socket.

Note: the pole (+) of the charger output plug correspondences the hole (+) of the battery socket.

the pole (-) of the charger output plug correspondences the hole (-) of the battery socket.

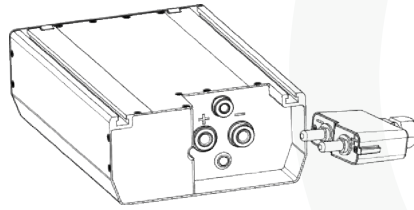

4.4.4.4.4 The battery is charged by power supply. The charging consists of two processes: constant-current charging and constant-voltage charging.

In the process of constant-current charging, the LED light is red colored; in the process of constant-voltage charging, the light is yellow colored; and when the charging is completed, the light is green colored.

4.4.4.4.5 In the process of charging, the integrated fan is running to dissipate heat.

Note: If the battery is connected with the charger but not charged by a power supply, the battery will discharge gradually until it cannot be recharged.

Danger! In order to prevent accident, battery charging is forbidden in unattended condition.

4.4.5 Remote Control

4.4.5.1 The remote control is used for rescue or transporting tools and materials only. The user can control the device operation of ascending or descending by the commands issued from the matched remote control. Before the remote-control function is adopted as a formal rescue plan, a practice of simulative rescue shall be performed in safe environment, and other rescue plans available as well.

4.4.5.2

If the remote control is switched off, it cannot control the device further.

4.4.5.3 Two speeds of ascending and descending can be selected on the remote control: low speed and high speed (respectively 25% and 75% of the maximum speed).

No.	Item	No	Item
1	Signal transmission indicator light	2	Low battery voltage indicator light
3	Clockwise high speed button	4	Clockwise low speed button
5	Anti-clockwise high speed button	6	Anti-clockwise low speed button

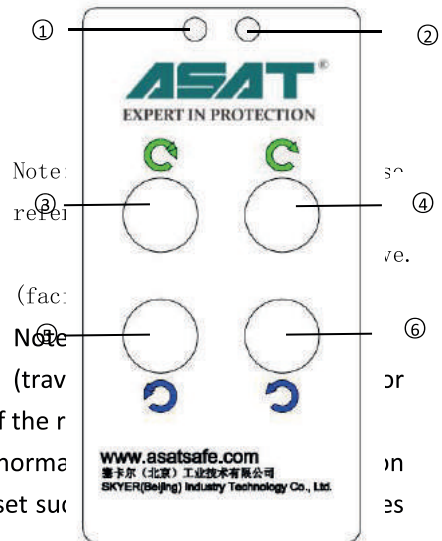

rightwards) depends on the rope rigging and rotation direction of the r
 4.4.5.4 When the driver issues warning, the device cannot work norma
 on the remote control for 3 seconds to reset the driver. After reset suc
 its normal working condition.

Note: The maximum remote-control distance can be reached only in case of excellent visibility between the remote control and the device.

Pull out the antenna of the device in case of remote-control model.

4.4.6 Overload and overheat protection

4.4.6.1 The device monitors the load on itself in real time. In case of overloaded, the device will run at a low speed or stop running automatically and switch off.

4.4.6.2 The internal temperature of the device is monitored in real time. The temperature warning light is lit at first and the device will stop running in case of overheating. Once the temperature drops in the normal range, the warning is eliminated and the device resumes its normal working condition.

5、 Operation

Note: The associated safety rope must be set up in case of non-emergency.

Note: There is risk of falling objects when the user is working at heights; protective measures shall be taken to barrier the dangerous area in order to prevent the unauthorized personnel entering.

Note: The user working at heights must always keep the device and his portable tools connected with himself reliably.

5.1 Rope rigging

5.1.1 Working rope rigging

5.1.1.1 Press down the self-lock knob of the hinged steel band, lift up the lock handle of the hinged steel band to release the hinged steel band, as shown in the figure.

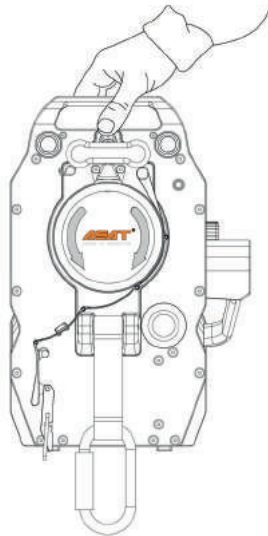

5.1.1.2 Make a loop on the rope, press the guide block by one hand, and by the other hand, pass the rope loop through the guide block and rope separator inside of the U-shaped fender, and reeve the rope on the rope sheave and tension it.

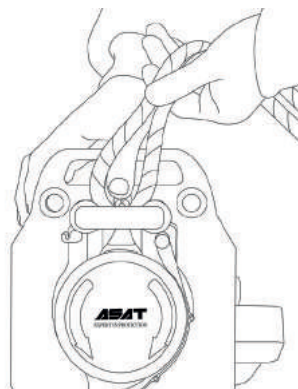

Note: Ascending or descending of the device depends on the rotation direction of the rope sheave and anchor direction of the working rope. Therefore, the device configuration shall be clarified before operation in order to prevent maloperation.

5.1.1.3 Attach the hinged steel band to its hook, adjust it to the correct position and press down its lock handle. Try to lift up the lock handle of the hinged band to check whether the hinged steel band is locked firmly. To remove the rope, press down the self-lock knob before lift up the lock handle of the hinged steel band.

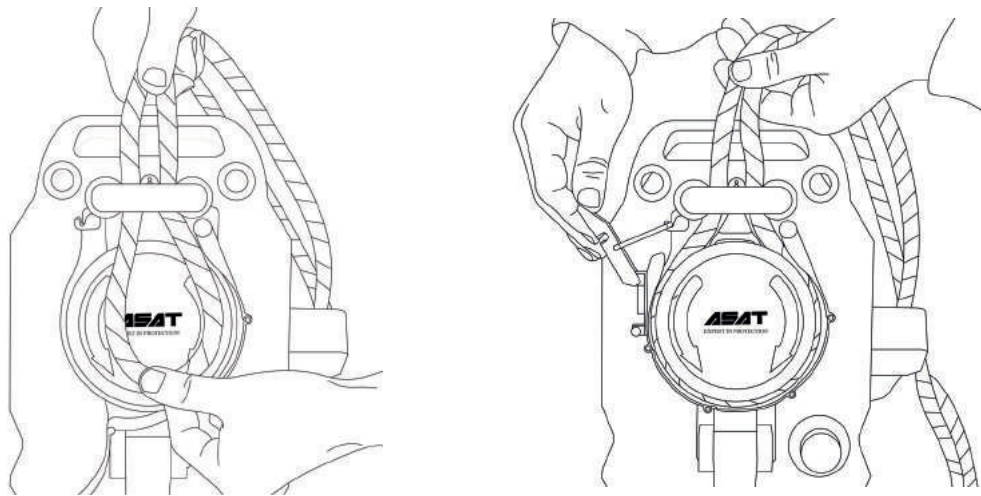

5.1.2

Attaching the device with the associate safety rope. The associated safety rope must be set up in case of non-emergency.

5.1.2.1 Attach the fall arrester onto the safety rope, connect the fall arrester with the connection hole at the left side near the U-shaped fender.

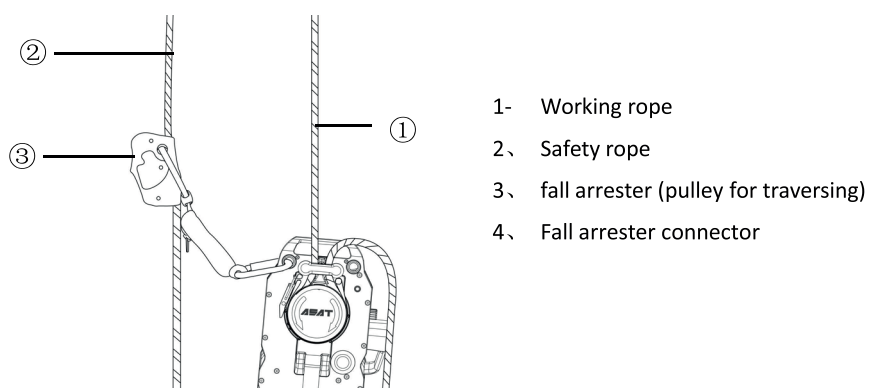

④ —————

Note: During traversing horizontally or inclinedly, the lanyard between the safety rope and the device as well the safety rope shall keep slack and have no significant pulling force to the device in order to avoid effecting the normal operation of the device, as shown in the figure:

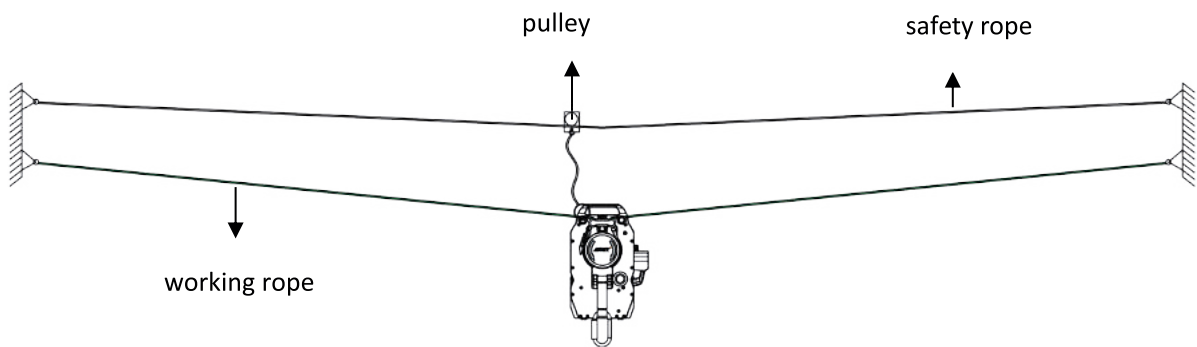

5.1.2.2 Connect the carabiner of the device with the ventral attachment point of user's harness.

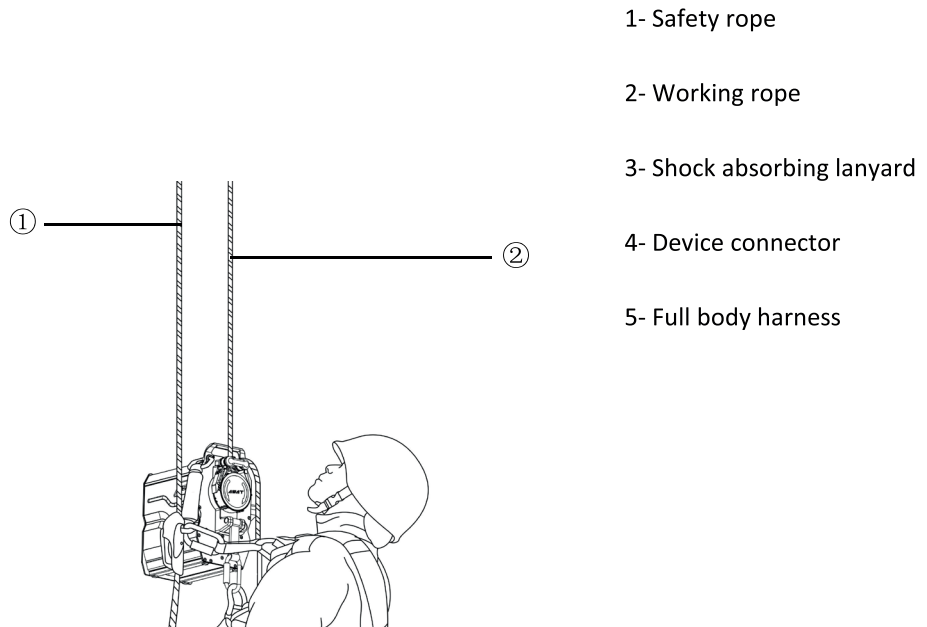

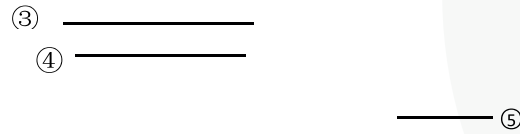

5.2 Running: Ascending, descending, traversing horizontally or inclinedly

Press the power button to energize the device. The battery level indicator light presents the battery level when the emergency stop button is pulled up.

When used only by one person (light load) with sufficient battery level, the device can run at a high speed; when used by carrying heavy load or with insufficient battery level, the device shall run at a low speed.

When the thumb shifter is pushed upward or forward, the rope sheave will rotate anticlockwise;

When the thumb shifter is pulled downward or backward, the rope sheave will rotate clockwise. The running direction of the device depends on the rotation direction of the rope sheave and the rope rigging. The farther the thumb shifter is moved, the faster the rope sheave rotates.

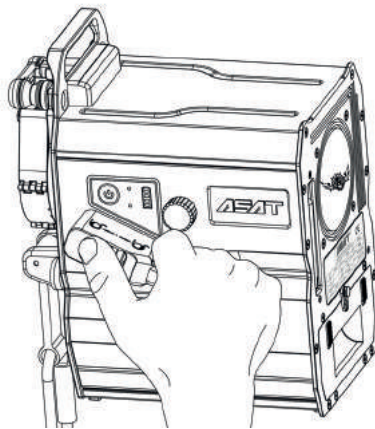

In case of traversing horizontally or inclinedly, as the tension force on the rope is much larger than the load carried by the device, the running and accelerated speed of the device shall be gently to avoid rope damage and ensure safety; in addition, as the running direction of the device and direction of gravity are different, which results in the device and its carried load swinging at start and stop process, slow start and decelerated stop will reduce the swing of the device and ensure personal safety.

Note: In case of ascending vertically, in order to reduce the twisting stress in the rope, start the device ascending off the ground and suspend for several seconds to release the twisting stress in the

rope, and then ascend continually.

Note: It is suggested to start the device ascending off the ground and suspend for a while to adjust the body posture, and the positions of the rope and device properly.

Note: Control the running speed of the device coordinated with that of the fall arrester. If the running speed of the device exceeds the engaging speed of the fall arrester, as a result, the fall arrester will engage on the safety rope and restrain the normal running of the device. Such situation tends to occur in case of descending.

Note: The device will stop running as soon as the thumb shifter is released at any time.

Note: To stop the running of the device, slow down its speed in advance. It needs a distance to slow down the speed of the device from running to stand still.

Note: Ensure that the rope passes through the device smoothly in operation. Twisting of the working rope may result in the rotation of the user and tangle of the working and safety ropes during the running of the device, which is dangerous to the user. Therefore, user must eliminate twisting of the rope before ascending.

Danger! Do not grasp the rope section above the device during ascending or the rope section below the device during descending. Do not grasp the rope section at front along the running direction of the device during traversing. Otherwise, the hands may be crushed.

5.3 Emergency stop

When the emergency stop button is pressed, the device will stop running immediately and only one red LED is lit on the battery level indicator light. When the emergency stop button is released by turning it clockwise, the battery level will present normally and the device resume the normal working condition.

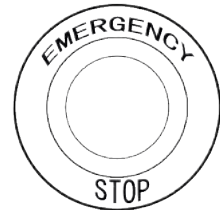

Note: During working at heights, press the emergency stop button to prevent maloperation.

Note: After the device is powered off or before it is powered on, press the emergency stop button to prevent maloperation.

5.4 Manual descending

The device is fitted with manual descending function. When the device is running along vertical working rope but the battery is run-down or out-of-work, user can descend to the ground safely by the function of manual descending.

Manual descending steps :

5.4.1 Power off the device (shutdown)

5.4.2 Press the emergency stop button.

5.4.3 Unscrew the sealing cover of the manual descending lever

5.4.4 Push the manual descending level to right to descend the device.

The greater the pushing force, the faster the descending speed.

5.4.5 Once the manual descending level is released, the descent stops.

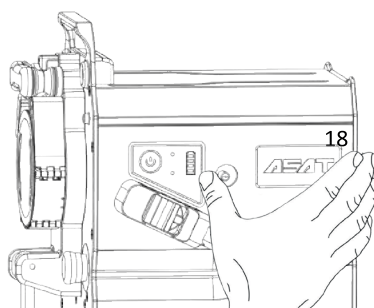
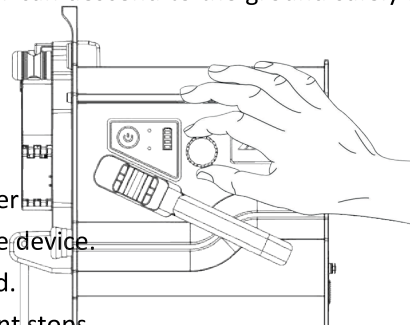

Note: Do not use manual descending continuously over a long distance.

Note: the manual descending is related to the load carried by the device and the rope angle of traversing inclinedly or horizontally. The manual descending is not available in some cases.

Note: Regulate the descending speed according to the actual situation. In order to ensure the safety of the user, the manual descending speed shall not be too fast.

Note: Manual descending may cause impairment of the driver and slowing down the descending speed may relieve the situation.

Danger!! In case the device is powered on and operated normally, if manual descending is required, it is necessary to turn off the power supply, press the emergency stop button, and then descend manually; otherwise not only the manual descending function is not available but also the device will be damaged.

5.5 Use of remote control

Before using the remote control, ensure that the device is powered on, the emergency stop button released and the antenna of the device pulled out.

5.5.1 The running direction of the device shall be determined according to the rigging of the working rope and the rotation direction of the rope sheave.

5.5.2 When corresponding speed/direction button is pressed, the device will run at the speed and in the direction as selected.

5.5.3 In case the device cannot operate normally with warning issued from the driver, press and hold any button for 3 seconds, then release it to reset the driver. After resetting successfully, the device resumes the normal working condition.

Note: The remote control is used only with the matched device and its availability shall be confirmed before use.

Note: If the device cannot be observed during operation, do not activate the remote control to prevent risks.

Note: Keep good visibility between the remote control and the device in order to reach the maximum remote-control distance.

Note: If the operation of the device controlled by the remote control is unstable owing to the long distance between the device and the remote control, shorten the distance by approaching the device with the remote control immediately to prevent out of control to the device!

6、Associated equipment

6.1 Harnesses: The device can only be used with the full-body sit harnesses in accordance with EN361, EN358 and EN813.

6.2 Anchor point: The anchor points connected with the device shall be in accordance with EN795 or ANSI/ASSE Z359.15:2014.

Selection of anchor points is crucial to safety. The anchor positions should keep the rope away from sharp edges or subjects. If necessary, use the rope protector provided by SKYER to protect the ropes.

6.3 Connecting parts: The connecting parts as follows can be selected for use with the device:

Lanyards in accordance with EN354 or EN795.

Work positioning lanyards in accordance with EN358.

Connectors in accordance with EN362

6.4 Ropes

The dedicated ropes for the device from SKYER are recommended. If other ropes are selected instead, the properties shall be confirmed by a competent person.

6.5 Associated safety system

7.: Check and inspection

7.1 Daily check:

7.1.1 The device shall be checked by a competent person before each use. The check items are as follows:

7.1.1.1 U-shaped fender: no excessive abrasion;

7.1.1.2 Hinged steel band assembly: no solder joints off, no cracks on the hook, flexible hinge joints, normal hook function;

7.1.1.3 Guide block: no looseness, no excessive abrasion

7.1.1.4 Rope separator: no excessive abrasion.

7.1.1.5 Carabiner: no cracks, no rusting, normal locking function.

7.1.1.6 Device casing, especially at the area of the load bearing rod: no screw looseness.

7.1.1.7 Normal conditions of operating buttons, speed/direction thumb shifter and remote control;

7.1.1.8 Sufficient battery level for the working task;

7.1.2 Check of working and safety ropes, including the surface layer, the sewn ends and the diameter.

7.1.3: Check of associated equipment.

7.1.4 Check record of the device in 12 months.

7.1.5 After each use, the device must be checked by a competent person to ensure that no damage is found after the operation, and check result recorded.

7.1.6 The periodical inspection of device must be carried out at least every 12 months by competent persons and the inspection result recorded in Annual Inspection Record Sheet.

Note! The inspection result of the device must be filled in Annual Inspection Record Sheet provided by SKYER.

Note! If any defect dealing with safety is found, never use the device further and send it to a qualified agent of SKYER for repair.

7.2 Refer to section 12 for Annual Inspection Record Sheet.

8、Storage, Transportation, Maintenance and Overhaul

8.1 Storage:

The device shall be placed in a box, which is light-proof, moisture-proof and chemical-proof, during storage and transportation.

The device shall be stored in the environment of normal atmospheric temperature.

Recommendation: Use the dedicated box from SKYER to store the device.

8.2 transportation:

For short distance handling, user can carry the device with the handles on the device top.

For long distance transportation, the device shall be packed well.

8.3 Maintenance:

Clean the device including the rope sheave, U-shaped fender, rope guide pulley, hinged steel band assembly, rope separator, guide block and carabiner regularly. Blow any residual rope scraping off the rope sheave, U-shaped fender, rope guide pulley, hinged steel band assembly, guide block and rope separator by a pneumatic blowing device. Lubricate required components.

8.4 Overhaul:

Danger!

If any abnormality, such as fault or defect, is found in any check or inspection, the device must be overhauled by competent persons!

9、 Service life

The quick-wear parts of the device and their service life are listed as follows:

9.1. U-shaped fender and rope guide pulley: they must be replaced if the abrasion loss is more than 1/5.

9.2 Battery: it must be discarded if the device, carrying 120 kg of load and powered by the battery fully charged, can ascend and descend less than 100 m totally in circles of about 10 m. Test the battery with the principle mentioned above after 4 years of use to decide whether it shall be discarded.

9.3 Rope sheave: It must be replaced if the device, carrying a load of about WLL, slips during normal and accelerated ascending along a new rope of 11 mm diameter conforming to EN1891.

9.4 Hinged steel band assembly: It must be replaced if any cracks or excessively abrasion on it;

9.5 Rope

Note: The service life of the rope is closely related to the operating conditions.

The service life of the rope shall be greatly shortened if the device is used in severe conditions, such as in extreme temperature environment, in contact with chemicals, sharp edges or rough surfaces.

If any doubt to its property for safety, the rope must be replaced immediately.

The rope must be replaced every 5 years even under conditions of normal use, proper maintenance, check before each use by a competent person.

10、 Markings

10.1 Label of brand and technical parameters



Power ascender



Model	ACE-24	Rated power	1.25kW	Rated working load	180kg
S/N		Weight	18kg(incl. battery)	Working load limit	260kg
Production date		Capacity	7.5Ah	Speed	0~30m/min
Textile rope	Φ11mm	Rated voltage	48VDC	Size	30x23x35cm

SKYER(Beijing) Industry Technology Co., Ltd

10.2 Label on rope sheave;



10.3 Tag on rope:

 <p>Rope 机械静态绳索 EN1891A:1998 S/N:11A52320305 生产许可证号:(京)XX02-001-01119</p>	<p>TYPE/类型:AR-TS03-11 Date/日期: 2022-11 Lengths/长度: m DIA/直径: 11mm Breaking load/破断拉力: 32kN</p> <div style="display: flex; justify-content: space-between; align-items: center;">   <p style="font-size: small;">塞卡尔(北京)工业技术有限公司 生产工厂:阿萨特(廊坊)高空装备有限公司</p> </div>
---	---

11、 Fault, cause and remedy

If any problems cannot be solved by referring this manual, please contact SKYER or its distributors.

Fault	Cause and remedy
The device cannot be energized when the power button is pressed.	The battery is run-down or damaged.
The device cannot ascend and descend after energized.	The emergency stop button is not released, the device is overloaded or the driver issues a fault warning.
The remote control cannot control the operation of the device.	1、 There are obstacles between the remote control and the device.
	2、 The battery of the device is run-down.
	3、 The device is not powered on.
	4、 The distance between the remote control and the device is too far or the antenna is not pulled out.
	5、 The remote control is short of power.
	6、 The remote control does not match with the device.
	7、 The remote control or the device is damaged.
The device stops operation even with fully charged battery.	1、 The motor temperature is too high.
	2、 The battery temperature is too low.
	3、 The charger is damaged.
	4、 The battery is aged or failed.
Slippage between rope and rope sheave.	1、 The rope is damaged.
	2、 The rope sheave is aged or worn.
	3、 The rope does match with the rope sheave.
Driver warning light M flashes	Reset the driver. If the fault still cannot be eliminated contact SKYER after descending manually.
Temperature warning light T flashes	The motor temperature is too high. Shut down the device for cooling.
The power indicator light on the remote control flashes red.	The Battery level of the remote control is insufficient.
	2、 The remote control is damaged.

12、Annual Inspection Record Sheet



ASAT powered ascending device annual inspection record sheet

Customer:		
Product /Model:		
Serial Number		Inspection site
		Inspection date
No.	Inspection item	Result
1	U-shaped fender and rope guide pulleys	
2	Hinged steel band assembly	
3	Guide block	
4	Rope separator	
5	Carabiner	
6	Casing	
7	Buttons, battery level indicator light, speed/direction thumb shifter, remote control	
8	Charger	
9	Battery	
10	Rope	
11	Rope sheave	
Inspection conclusion		
Inspected by (Signature)		



ASAT powered ascending device annual inspection record sheet

Customer:		
Product /Model:		
Serial Number		Inspection site
		Inspection date
No.	Inspection item	Result
1	U-shaped fender and rope guide pulleys	
2	Hinged steel band assembly	
3	Guide block	
4	Rope separator	
5	Carabiner	
6	Casing	
7	Buttons, battery level indicator light, speed/direction thumb shifter, remote control	
8	Charger	
9	Battery	
10	Rope	
11	Rope sheave	
Inspection conclusion		
Inspected by (Signature)		



ASAT powered ascending device annual inspection record sheet

Customer:		
Product /Model:		
Serial Number	Inspection site	Inspection date
No.	Inspection item	Result
1	U-shaped fender and rope guide pulleys	
2	Hinged steel band assembly	
3	Guide block	
4	Rope separator	
5	Carabiner	
6	Casing	
7	Buttons, battery level indicator light, speed/direction thumb shifter, remote control	
8	Charger	
9	Battery	
10	Rope	
11	Rope sheave	
Inspection conclusion		
Inspected by (Signature)		



ASAT powered ascending device annual inspection record sheet

Customer:		
Product /Model:		
Serial Number		Inspection site
		Inspection date
No.	Inspection item	Result
1	U-shaped fender and rope guide pulleys	
2	Hinged steel band assembly	
3	Guide block	
4	Rope separator	
5	Carabiner	
6	Casing	
7	Buttons, battery level indicator light, speed/direction thumb shifter, remote control	
8	Charger	
9	Battery	
10	Rope	
11	Rope sheave	
Inspection conclusion		
Inspected by (Signature)		



SKYER (Beijing) Industry Technology Co.,Ltd.
26B, West Zone, LianDo U Valley, No.17 Huan Ke Zhong Lu,
Tong Zhou District, Beijing, PR China 101102
Tel: +86-10-59770510
[Http://www.asatsafe.com](http://www.asatsafe.com)

